

ARCHANGEL 5 815 CHANDELIER

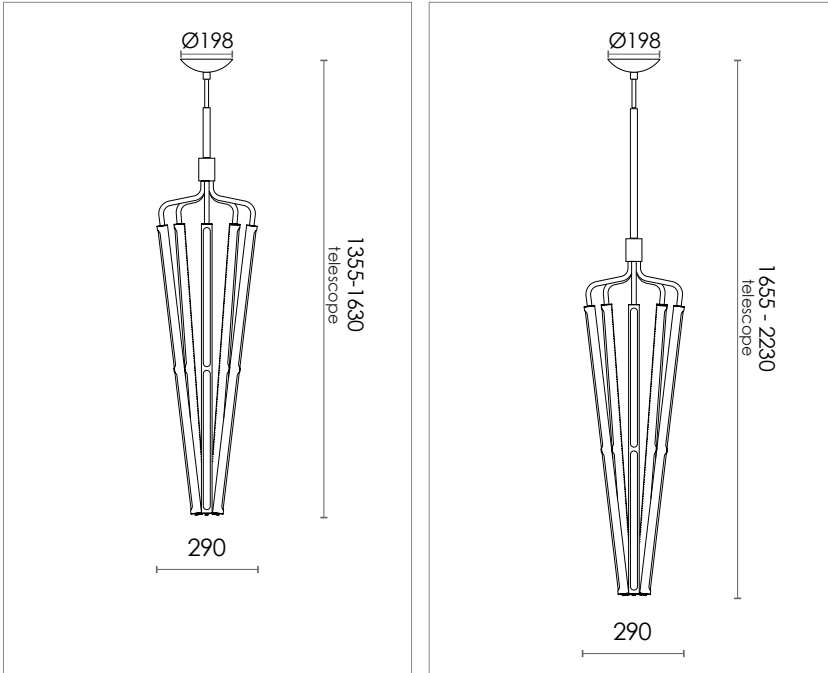



DESIGN SPECIFICATIONS

| | |
|------------------------|--|
| DIMENSIONS (mm) | W 290 x H 1355-1630 W 290 x H 1655-2230 |
| WEIGHT (kg) | 5kg / 6kg |
| MATERIALS | THE LAMP IS MADE FROM CLEAR LACQURED BRASS OR POWDER COATED STEEL. |
| CORD (mm) | NO |
| ENVIRONMENT | INDOOR |
| DESIGN BY | NICLAS HOFLIN |
| DESIGN YEAR | 2023 |

ELECTRICAL SPECIFICATIONS

| | |
|---------------------|-----------------------------------|
| SWITCH | NO |
| LIGHT SOURCE | INTEGRATED LED 58W - 2700 K |
| DIMMABLE | YES |
| MAX (W) | 58W |
| VOLTAGE | 230 / 240 |
| CLASS | 2 |
| IP | 20 |

COLOURS

| | | |
|---|--|-------------------------------|
|  | BLACK H 1355-1630 ART.NO. 815108005 | H 1655-2230 ART.NO. 815109005 |
|  | BRASS H 1355-1630 ART.NO. 815108001 | H 1655-2230 ART.NO. 815109001 |