

ARCHANGEL 3 415 CHANDELIER

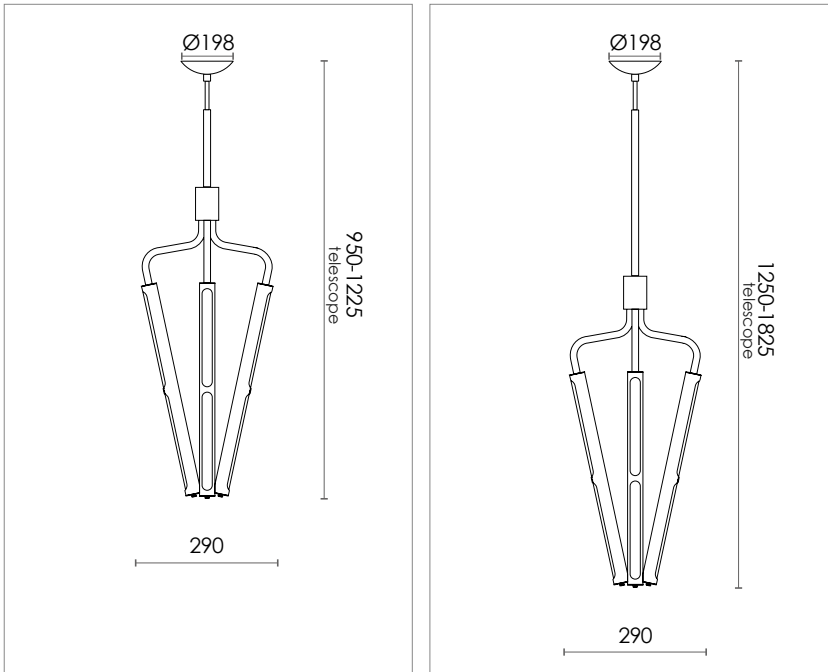



DESIGN SPECIFICATIONS

DIMENSIONS (mm)	W 290 x H 950-1225 W 290 x H 1250-1825
WEIGHT (kg)	3.5kg / 4,5kg
MATERIALS	THE LAMP IS MADE FROM CLEAR LACQURED BRASS OR POWDER COATED STEEL.
CORD (mm)	NO
ENVIRONMENT	INDOOR
DESIGN BY	NICLAS HOFLIN
DESIGN YEAR	2023

ELECTRICAL SPECIFICATIONS

SWITCH	NO
LIGHT SOURCE	INTEGRATED LED 18 W - 2700 K
DIMMABLE	YES
MAX (W)	18 W
VOLTAGE	230 / 240
CLASS	1
IP	20

COLOURS

	BLACK H 950-1225 ART.NO. 813104005	H 1250-1825 ART.NO. 813105005
	BRASS H 950-1225 ART.NO. 813104001	H 1250-1825 ART.NO. 813105001