

# GRACE WALL / CEILING

## DESIGN SPECIFICATIONS

<b>DIMENSIONS (mm)</b>	H 115 x W Ø240 BASE Ø100
<b>WEIGHT (kg)</b>	0,9
<b>MATERIALS</b>	THE LAMP IS MADE FROM CLEAR LACQURED BRASS, STEEL OR POWDER COATED STEEL AND CRYSTAL GLASS
<b>CORD (mm)</b>	NO
<b>ENVIRONMENT</b>	INDOOR
<b>DESIGN BY</b>	NICLAS HOFLIN
<b>DESIGN YEAR</b>	2019

## ELECTRICAL SPECIFICATIONS

<b>SWITCH</b>	NO
<b>BULB HOLDER</b>	GX53
<b>LIGHT SOURCE</b>	INCLUDED DIMMABLE 6 W - 2700K
<b>DIMMABLE</b>	YES
<b>MAX (W)</b>	10 W LED (LED DRIVER INCL.)
<b>VOLTAGE</b>	230 / 240
<b>CLASS</b>	1
<b>IP</b>	20

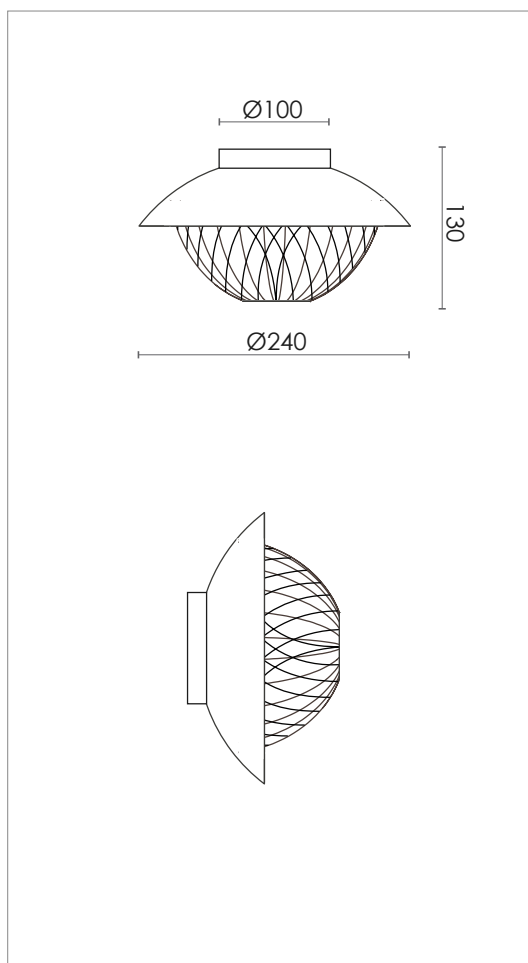

## COLOURS

	BLACK / CRYSTAL	ART.NO. 655220005
	BRASS / CRYSTAL	ART.NO. 655220001
	BRONZE- COLOR / CRYSTAL	ART.NO. 655220223
	STEEL / CRYSTAL	ART.NO. 655220500